12.0 WARRANTY

ELECTROMATIC Equipment Co., Inc. (ELECTROMATIC) warrants to the original purchaser that this product is of merchantable quality and confirms in kind and quality with the descriptions and specifications thereof. Product failure or malfunction arising out of any defect in workmanship or material in the product existing at the time of delivery thereof which manifests itself within one year from the sale of such product, shall be remedied by repair or replacement of such product, at ELECTROMATIC's option, except where unauthorized repair, disassembly, tampering, abuse or misapplication has taken place, as determined by ELECTROMATIC. All returns for warranty or non-warranty repairs and/or replacement must be authorized by ELECTROMATIC, in advance, with all repacking and shipping expenses to the address below to be borne by the purchaser.

THE FOREGOING WARRANTY IS IN LIEU OF ALL OTHER WARRANTIES, EXPRESSED OR IMPLIED, INCLUDING BUT NOT LIMITED TO, THE WARRANTY OF MERCHANTABILITY AND FITNESS FOR ANY PARTICULAR PURPOSE OR APPLICATION. ELECTROMATIC SHALL NOT BE RESPONSIBLE NOR LIABLE FOR ANY CONSEQUENTIAL DAMAGE, OF ANY KIND OR NATURE, RESULTING FROM THE USE OF SUPPLIED EQUIPMENT, WHETHER SUCH DAMAGE OCCURS OR IS DISCOVERED BEFORE, UPON OR AFTER REPLACEMENT OR REPAIR, AND WHETHER OR NOT SUCH DAMAGE IS CAUSED BY MANUFACTURER'S OR SUPPLIER'S NEGLIGENCE WITHIN ONE YEAR FROM INVOICE DATE.

Some State jurisdictions or States do not allow the exclusion or limitation of incidental or consequential damages, so the above limitation may not apply to you. The duration of any implied warranty, including, without limitation, fitness for any particular purpose and merchantability with respect to this product, is limited to the duration of the foregoing warranty. Some states do not allow limitations on how long an implied warranty lasts but, notwithstanding, this warranty, in the absence of such limitations, shall extend for one year from the date of invoice.

ELECTROMATIC Equipment Co., Inc.
600 Oakland Ave. Cedarhurst, NY 11516—USA
Tel: 1-800-645-4330/ Tel: 516-295-4300/ Fax: 516-295-4399

TABLE OF CONTENTS

1.0	Introduction	2
2.0	Overview	3
	2.1 Operating Elements	
	2.2 Installing And Replacing The Battery	
	2.3 Turning The Power On and Off	
	2.4 Reversing The Display	
	2.5 Selecting The Unit Of Measure	
	2.6 Zero Adjustment of the Measurng Position	
3.0	Removing and Re-Mounting The Filament Guide	6
4.0	Taking A Measurement	7
	4.1 Inserting The Process Material	
	4.2 Measuring	
	4.3 Removing The Process Material	
5.0	Damping Mode	
	5.1 Switching On The Damping Mode	
	5.2 Switching Off The Damping Mode	
	5.3 Changin the Damping Factor	
6.0	Storing and Recalling Tension Values	9
	6.1 Storing Tension Values	
	6.2 Recalling Tension Values	
	6.3 Clearing Values Stored In Memory	
	6.4 Memory HOLD Function	
	6.5 Error Messages	
7.0	Static Verification of Measuring Accuracy	19
8.0	Calibration	20
	8.1 Dynamic Calibration	
	8.2 Static Calibration	
	8.3 Error Messages	
	8.4 Restoring Factory Defaults	
9.0	Specifications	24
10.0	Appendic A - Optional Accessories	25
11.0	Appendix B - Replacing the Rollers / Ceramic Pins	26
12.0	Warranty	28

Every precaution has been taken in the preparation of this manual. Electromatic Equipment Co., Inc., assumes no responsibility for errors or omissions. Neither is any liability assumed for damages resulting from the use of information contained herein. Any brand or product names mentioned herein are used for identification purposes only, and are trademarks or registered trademarks of their respective holders.

1.0 INTRODUCTION

Three long, closely-spaced slender shafts with precision guide rollers or pins at their ends combine with the latest in microprocessor technology to make this instrument top choice for all limited-access, tension measuring applications.

Choice of miniature, high speed rollers for filament speeds up to 2000 m/min or non-rotating, ceramic pins for speeds to 6000 m/min. Uses part number ETMB or ETMPB to designate model with ceramic pins.

Available Models - The standard series is also available with the following modifications. (Special calibration using customer supplied material.)

1.1 Unpacking

Unpack the tension meter and inspect it for any shipping damage. Notice of defect must be filed immediately, in writing, at the latest, within 10 days of receipt of the goods.

Delivery includes:

- Tension meter with 9V long life battery
- 1 Open end wrench (4mm jaw width)
- 1 screwdriver (1.5mm blade width)
- 1 ETMB-CC: Digital connecting cable
- 1 ETMB-P2: TENSION INSPECT software (Win 95 or higher) for viewing and storing the measured data on a PC
- 1 Operating instructions
- 1 carrying case

5. Slide the FILAMENT GUIDE up the ROLLER SHAFTS in the direction of the arrow.

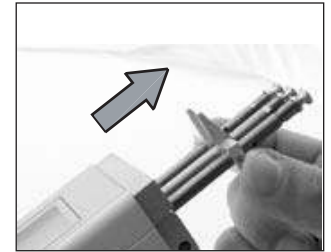

6. Push the FILAMENT GUIDE upward far enough to ensure that the ROLLERS do not rub against the FILAMENT GUIDE and that the process material can slide unhindered into the roller grooves. (Center Line.)

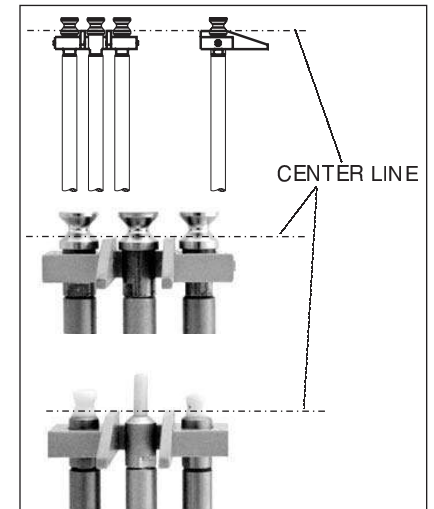

7. Tighten the GRUB SCREWS with the supplied screwdriver



11.0 APPENDIX B - REPLACING THE ROLLERS/CERAMIC PINS

NOTE: Replacing ceramic pins or converting from rollers to ceramic pins can only be performed at the factory

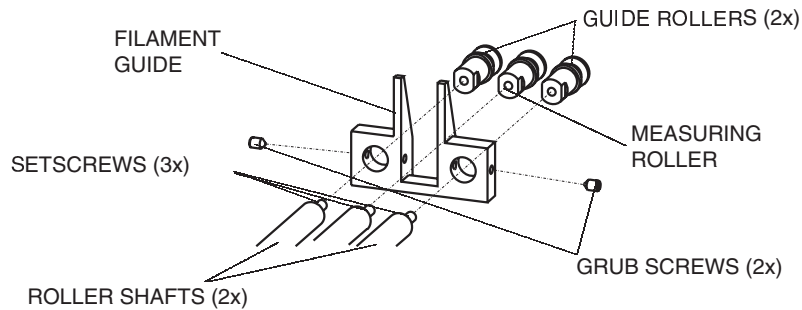

Procedure:

1. Remove the FILAMENT GUIDE by loosening the GRUB SCREWS using the supplied screwdriver (1.5m blade width).
2. Slide the FILAMENT GUIDE down the ROLLER SHAFTS in the direction of the arrow.
3. Unscrew and remove the GUIDE ROLLERS (2X) using the supplied open end wrench (4mm jaw width)
4. Carefully screw the new GUIDE ROLLERS onto the ROLLER SHAFTS using the supplied open end wrench (4mm jaw width) until hand tight.

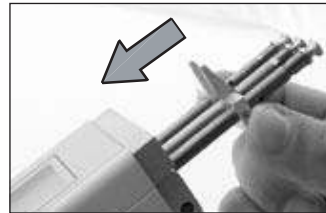

IMPORTANT: When tightening the rollers, steady the roller bolts with the supplied screwdriver to prevent the ROLLER SHAFTS from being twisted off.

2.0 OVERVIEW

2.1 Operating Elements

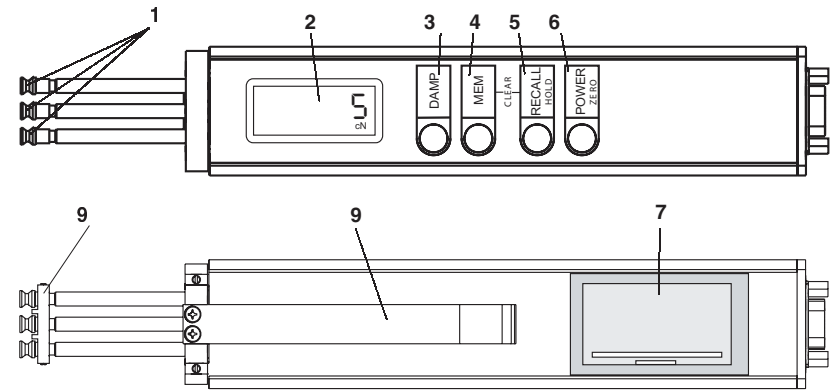

- | | |
|----------------------------|------------------------|
| 1. Rollers or ceramic pins | 6. POWER / ZERO key |
| 2. DISPLAY | 7. Battery Compartment |
| 3. DAMP key | 8. Lever |
| 4. MEM key | 9. Filament Guide |
| 5. RECALL / HOLD key | |

2.2 Installing and Replacing the Battery

Before first use of your tension meter, you need to insert the battery as described below:

1. Open the BATTERY COMPARTMENT (8) on the rear side of the tension meter.
2. Insert a 9 V battery (E block) into the BATTERY COMPARTMENT. Please ensure proper polarity.
3. Close the BATTERY COMPARTMENT.

NOTE: If the  symbol appears on the DISPLAY, the battery is low and must be replaced immediately. Operating the tension meter with a low battery may cause measurement errors.

NOTE: If the instrument will not be used for a lengthy period of time, the battery should be removed

2.3 Turning the Power On and Off

Power On: To turn the power ON, press the POWER key (6) until all symbols are shown on the display. When you release the key, the DISPLAY momentarily shows the tension range, followed by random values or “0.”



Manual Power Off: To turn the power off, press and hold the POWER key for five seconds.

Auto Power Off: The tension meter switches off automatically after three minutes of non-use.

2.4 Reversing the Display

When you shift the tension meter from the right to the left hand, you can rotate the readings on the DISPLAY by 180°.

Measuring with the left hand

If you would like to use the left hand for measuring, you should reverse the readings on the DISPLAY to make them easier to read. To accomplish this, follow the procedure below:

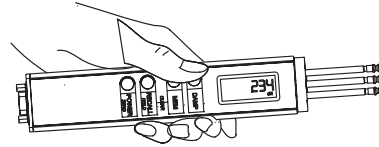

1. Press and hold the POWER key for five seconds until the gauge turns itself off.
2. Press and hold the DAMP and POWER keys until the DISPLAY shows the readings reversed (“upside down”).

Returning to right hand measurement (default)

1. If the gauge is turned on, press and hold the POWER key for five seconds until the gauge turns itself off.
2. Press and hold the DAMP and POWER keys until the DISPLAY shows the readings reversed.

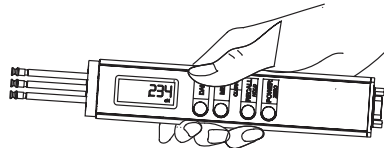

NOTE: The selected display orientation remains stored in the gauge memory even after the instrument is switched off.

2.5 Selecting the Unit of Measure

You can set the ETMB to the cN (default) or g (gram) unit of measure, depending on the required tension range, by following the procedure below:

1. Switch off the tension meter.
2. Press and hold the RECALL and POWER keys until the new unit of measure is indicated on the DISPLAY.

NOTE: The selected unit of measure remains stored in memory even after the instrument is switched off.

9.0 SPECIFICATIONS

Calibration	According to factory procedure
Units of Measure	cN / g, user selectable
Accuracy	± 1% FS* ± 1 digit (typically ± 0.5% FS*)
Overrange	10% FS*, without accuracy guarantee
Overload Protection	200% FS*
Measuring Principle	Strain gauge bridge
Meas. Roller Deflection	0.5mm, max
Signal Processing	Digital, 12 bit A/D converter
Damping	Adjustable electronically (averaging)
Measuring Frequency	Approx. 5 kHz internally
Display Update Rate	2x per second
Display	4-digit LCD, height of digit 0.43" (11mm)
Memory	Average, last value, maximum, minimum, MAX _{PEAK} , MIN _{PEAK}
Temperature Coefficient	Gain: less than ± 0.01% FS*/°C
Converter Frequency	30 MHz
Digital Output Signal	RS232 (9600, 8, N, 1) (2 readings per sec.)
Temperature Range	50 - 113 °F (10 - 45 °C)
Air Humidity	85% RH, max.
Auto Power Off	Automatically after approx. 3 min. of non-use
Power Supply	9 V E block e.g.: long life 9 V lithium for about 80 hours of continuous use
Housing Material	Aluminium profile with plastic outer casing (PVC)
Housing Dimensions L x W x H	9.10" x 2.44" x 1.89" (230mm x 62mm x 48mm)
Weight (net /gross)	Approx. 370 g / 1050 g

*FS = Full Scale

ETMB Guide Rollers

V-Groove	Line Speed m/min ... max.	Roller Material
Standard	2000	Hardcoated aluminium

ETMPB Guide Rollers

	6000	Oxide ceramic

10.0 APPENDIX A - OPTIONAL ACCESSORIES

ET-AC-115	Battery charger for 115 V AC
ET-AC-230	Battery charger for 230 V AC

8.4 Restoring Factory Calibration

You can restore the factory calibration at any time with the following procedure:

1. Switch off the tension meter.
2. Press and hold the MEM and POWER keys until the Display shows E-0 cN .
3. Release first the POWER key and then the MEM key.
4. Press and hold the DAMP and RECALL keys, then additionally press and hold MEM until the Display shows - - - cN .



The factory calibration is restored.

5. Release the DAMP, RECALL and MEM keys.
6. Press the POWER key. The instrument switches off.

2.6 Zero Adjustment of the Measuring Position (Auto Zero)

Each time the tension meter is turned on (before starting measurement), you need to carry out zero adjustment, as described below. This procedure is necessary to compensate for the weight of the measuring roller in the measuring position. The zero adjustment for the new measuring path only remains effective until the instrument is switched off.

NOTE: Zero adjustment must be repeated whenever the material path is changed or the tension meter does not display "0."

NOTE: Before beginning the zero adjustment, you must select the unit of measure as described in section 2.5.

1. Turn off the tension meter. Process material must not be inserted at this point.
2. Hold the gauge in the desired measuring position. Be careful to hold the gauge absolutely steady.
3. Press the POWER key. The DISPLAY momentarily shows $\square\square\square\square$ and then switches to 0. The gauge is now adjusted for the new material path and is ready to measure.

3.0 REMOVING AND REMOUNTING THE FILAMENT GUIDE

The tension meter is supplied with a filament guide for fast and easy material acquisition. For application in hard-to-reach areas with limited access space, you can remove the filament guide.

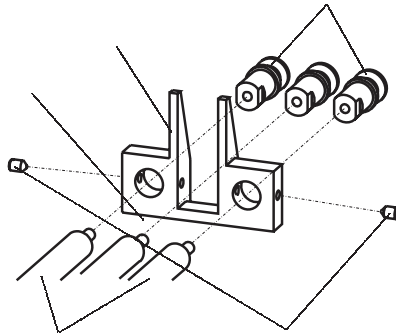

Removal Procedure

1. Loosen the GRUB SCREWS (2x) with the supplied screwdriver (blade width 1.5mm).
2. Unscrew and remove the GUIDE ROLLERS (2x) with the supplied open-end wrench (jaw width 4 mm).
3. Slip the FILAMENT GUIDE off the ROLLER SHAFTS.
4. Screw the GUIDE ROLLERS (2x) back on to the ROLLER SHAFTS and carefully tighten them with the supplied open end wrench (jaw width 4mm) until hand tight.

Re-Mounting Procedure

1. Unscrew and remove the GUIDE ROLLERS (2x) with the supplied open-end wrench (jaw width 4 mm).
2. Slip the FILAMENT GUIDE onto the ROLLER SHAFTS.
3. Screw the GUIDE ROLLERS (2x) back on to the ROLLER SHAFTS and carefully tighten them with the supplied open-end wrench (jaw width 4mm) until hand tight.
4. Push the FILAMENT GUIDE forward far enough to ensure that the rollers do not rub against the FILAMENT GUIDE and that the process material can slide unhindered from the FILAMENT GUIDE into the roller grooves
5. Carefully tighten the GRUB SCREWS (2x) with the supplied screwdriver until hand tight.

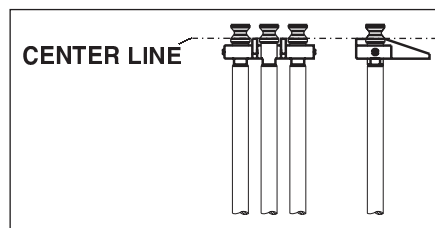

5. Release the MEM key when the value shown on the Display is stable. (The reading might fluctuate greatly).
6. The Display shows E-90 cN. If the display shows E-50cN again, the value was not accepted. Check the suspended weight and the material path between the MEASURING and GUIDE ROLLERS and repeat the procedure from step 4.

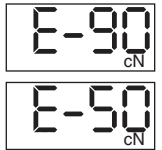

3rd calibration point:

1. Hang a weight which corresponds to 90% of the tension range from the measured material, vertically, as shown on page 21.
2. Press the LEVER down all the way. Thread the PROCESS MATERIAL through the MEASURING and GUIDE ROLLERS. Slowly release pressure on the LEVER until the GUIDE ROLLERS return to their original position.
3. Before starting the calibration, move the instrument slowly up and down to compensate for possible mechanical friction losses and thus ensure repeatability of the measurements.

4. Press the MEM key. Release the MEM key.
The Display shows - - - -cN . The new calibration has been stored.



If the display shows E-90 cN again, the value was not accepted. Check the suspended weight and the material path between the MEASURING and and repeat the procedure from step 4.



5. Press the POWER key. The instrument switches off.
6. Verify the new calibration, following the directions in section 8.0. If this procedure shows a deviation, you can recalibrate the tension meter again or restore the factory calibration. (section 9.4)

8.3 Error Messages During Calibration

The following error messages might be displayed during the calibration of the tension meter:

1. The Display shows EEE .
The weight suspended from the process material is too heavy.
2. The Display shows -EEE.
The weight suspended from the process material is too light.



1st calibration point:

1. Hang a weight which corresponds to 10% of the tension range from the measured material, vertically, as shown.

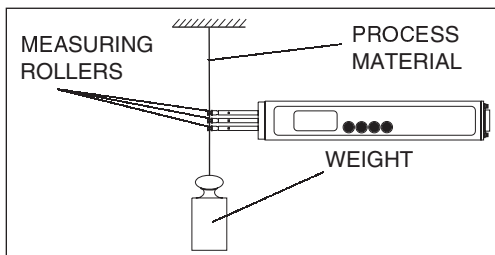

2. Press the LEVER down all the way. Thread the PROCESS MATERIAL through the MEASURING and GUIDE ROLLERS. Slowly release pressure on the LEVER until the GUIDE ROLLERS return to their original position.

3. Before starting the calibration, move the instrument slowly up and down to compensate for possible mechanical friction losses and thus ensure repeatability of the measurements.

4. Press the MEM key. As long as the key is depressed, the Display shows a decimal value which is higher by approx. 200 than the first decimal written down when setting the zero point, e.g. 1000 (800 + 200 equals approx. 1000).

5. This decimal value may vary from instrument to instrument. Write down the decimal value.

6. Release the MEM key when the value shown on the Display is stable. (The reading might fluctuate greatly.)

7. The Display shows E-50 cN. If the display shows E-10 cN again, the value was not accepted. Check the suspended weight and the material path between the MEASURING and GUIDE ROLLERS and repeat the procedure from step 4.

2nd calibration point:

1. Hang a weight which corresponds to 50% of the tension range from the measured material, vertically, as shown above.

2. Press the LEVER down all the way. Thread the PROCESS MATERIAL through the MEASURING and GUIDE ROLLERS. Slowly release pressure on the LEVER until the GUIDE ROLLERS return to their original position.

3. Before starting the calibration, move the instrument slowly up and down to compensate for possible mechanical friction losses and thus ensure repeatability of the measurements.

4. Press the MEM key. As long as the MEM key is depressed, the Display shows a decimal value which is higher by approx. 800 than the second decimal value, (1000 + 800 equals approx. 1800). The decimal value may vary from instrument to instrument. Write down the value.

4.0 TAKING A MEASUREMENT

NOTE: Before taking a measurement, be sure that the correct unit of measurement (g or cN) has been selected and a zero adjustment has been performed.

4.1 Inserting the process material

1. Press the LEVER to tilt the outer GUIDE ROLLERS sideways.
2. Thread the PROCESS MATERIAL through the MEASURING and GUIDE ROLLERS (filament guide).
3. Slowly release pressure on the LEVER until the GUIDE ROLLERS return to their original position.

NOTE: It is important to assure that the PROCESS MATERIAL runs smoothly between the MEASURING and GUIDE ROLLERS.

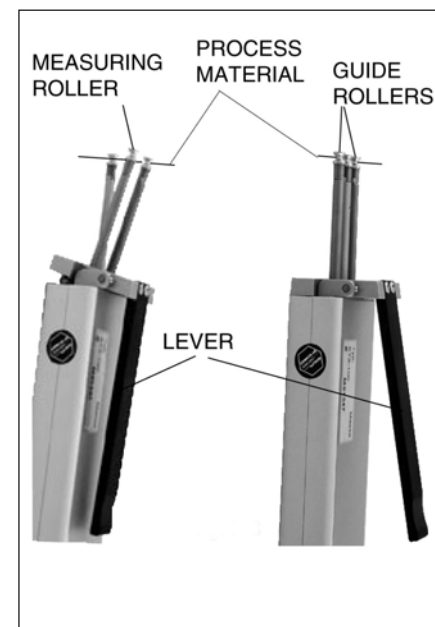

4.2 Measuring the process material

The DISPLAY now shows the measured tension values. Error messages which might be displayed are described in section 7.7.

4.3 Removing the process material

1. Press the LEVER and remove the PROCESS MATERIAL.
2. Slowly release pressure on the LEVER until the GUIDE ROLLERS return to their original position.

5.0 DAMPING MODE

The tension meter is equipped with an electronic damping that ensures steady readings when tension fluctuates. This is achieved by averaging the measured values at the preset update rate.

5.1 Switching On the Damping Mode

NOTE: Before switching on the damping mode, it is recommended that you measure the first values without damping enabled.

1. Insert process material as described in section 4.1.
2. Press and hold the DAMP key. The display shows the currently set damping factor.

3. Release the DAMP key. The display shows DAMP below the currently measured value.



5.2 Switching Off the Damping Mode

1. Press and release the DAMP key. If display shows only the currently measured value, damping is off.



5.3 Changing the Damping Factor

The tension meter is factory preset to a damping factor of 12. The tension values are thereby averaged for the display in the following way:

$$\frac{12 \text{ old values} + 4 \text{ new values}}{16}$$

The damping factor can be modified in 15 steps from 01 = low damping:

$$\frac{1 \text{ old value} + 15 \text{ new values}}{16}$$

to 15 = high damping:

$$\frac{15 \text{ old values} + 1 \text{ new value}}{16}$$

1. Switch on the tension meter
2. Press and hold the DAMP key. The Display shows the set damping factor.
3. You can now increase the damping factor by pressing the MEM key and decrease it by pressing the RECALL key.
4. Release the DAMP key to return to the measuring mode.

NOTE: The selected damping factor remains stored in memory even after the gauge is turned off.

8.0 CALIBRATION

8.1 Dynamic Calibration of the ETX

All tension meters are calibrated with standard materials—such as polyamide monofilament (PA)—according to the factory procedure. The diameters are given in section 1.0. In 95% of all industrial applications, the factory calibration has been proven to provide the best results and is used for comparative purposes. The basic setup for a dynamic calibration is shown below.

Line speed $V_{max.} = \text{ETX } 100 \text{ m/min} - V_{max.} = \text{ETXP } 60 \text{ m/min}$

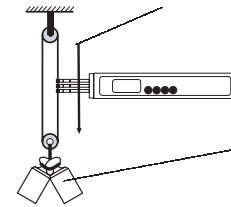

Hang twice the weight (pulley effect) which corresponds to the tension to be measured from the measured material, vertically, as shown here. Please keep in mind to include the weight of the lower deflection pulley when you calculate the suspended weight. Pay attention to the correct unit of measure cN.

8.2 Static Calibration

NOTE: The tension meter is factory calibrated for a vertical material path. Recalibration thus also has to be carried out with a vertical material path.

Before beginning:

Acquire one cN weight each (or several weights adding up to the required value), corresponding to 10%, 50% and 90% of the tension range. Make sure the tension meter is switched off and that no process material is inserted between the rollers.

To select the calibration mode:

1. Press and hold the MEM and POWER keys until the Display shows
2. Release first the POWER key and then the MEM key.

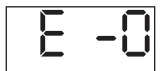

To calibrate the zero point:

1. Press the MEM key. As long as the MEM key is depressed, the Display shows a random decimal value between 500 and 1200, e.g. 800 cN. This decimal value may vary from instrument to instrument. Write down the decimal value.
2. Release the MEM key when the value shown on the Display is fairly stable (the reading might fluctuate greatly).
3. The Display shows



7.0 STATIC VERIFICATION OF MEASURING ACCURACY

All tension meters are calibrated with standard materials—such as polyamide monofilament (PA)—according to the factory procedure. The diameters are given in section 1.0. Any difference in process material size and rigidity from the standard material may cause a deviation of the accuracy.

In 95% of all industrial applications, the factory calibration has been proven to provide the best results and is used for comparative purposes.

NOTE: Before beginning, make sure that the tension meter is factory calibrated for a vertical material path. The required reference weight is available.

Verification procedure:

1. Switch on the tension meter.
2. Hang a weight which corresponds to the tension to be measured from the measured material, vertically, as shown.

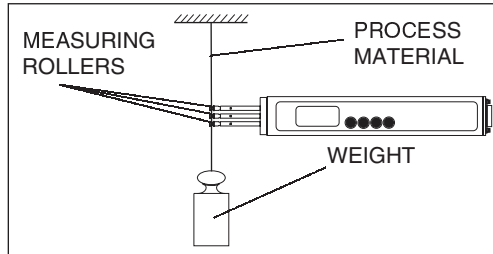

NOTE: Pay attention to the correct unit of measure cN or g (gram).

3. Press the LEVER down all the way and thread the process material through the MEASURING and GUIDE ROLLERS as described in section 4.1, then slowly release pressure on the LEVER until the GUIDE ROLLERS return to their original position.
4. Before verifying the calibration, move the instrument slowly up and down to compensate for possible mechanical friction losses and thus ensure repeatability of the measurements.
5. The tension value shown on the Display should be equal to the value of the suspended weight (pay attention to the measuring units).

If this procedure shows a deviation, you can recalibrate the instrument following the directions in section 9.0

6.0 STORING AND RECALLING TENSION VALUES

The tension meter features a data logger which stores the following data obtained during a measuring period:

- Average value
- Last value
- Maximum value (MAX),
- Minimum value (MIN),
- Minimum peak value (MIN PEAK)
- Maximum peak value (MAX PEAK)

NOTE: The measured data remain stored in the ETMB memory even after the instrument is switched off.

6.1 Storing Tension Values

NOTE: The stored tension values remain stored in the ETMB memory even after the instrument is switched off.

1. Turn off the tension meter.
2. Insert the process material.
3. Press the MEM key to start the measuring period.

While the tension data are stored, the MEM indicator blinks on the DISPLAY and the currently measured value is displayed.



When you want to end the measuring period, press the MEM key once again. Data logging is stopped.

The DISPLAY shows MEM and the current reading.



6.2 Recalling Stored Tension Values

1. Be sure that the tension meter is ON.

NOTE: You can end recall at anytime by pressing the POWER key.

2. Press the RECALL key (see page 5). The display blinks, showing the **average** value of the measuring period and the indicated symbol.



3. Press the RECALL key. The display blinks, showing the **last** value of the measuring period (no symbol).



4. Press the RECALL key. The display blinks, showing the **maximum** value of the measuring period and the indicated symbol.



5. Press the RECALL key. The display blinks, showing the **minimum** value of the measuring period and the indicated symbol.



6. Press the RECALL key. The display blinks, showing the **maximum peak** value of the measuring period and the indicated symbol.

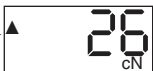

7. Press the RECALL key. The display blinks, showing the **maximum peak** value of the measuring period and the indicated symbol.



8. Press the RECALL key. The tension meter switches back to the **measuring mode**. The display shows MEM and the current reading.

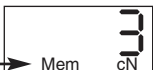

The tension meter is ready for a new measuring period.

6.3 Clearing Tension Values Stored In Memory

If values are stored in the tension meter memory, the DISPLAY shows with the MEM indicator.



1. To clear the memory, simultaneously press the MEM and RECALL keys (see page 5). The MEM indicator disappears and all values stored in memory are deleted.



6.4 Memory Function HOLD

When the tension meter memory is empty, you can retain the last reading on the Display by using the memory function HOLD.

To retain the last reading:

Press the RECALL / HOLD key once for about 1 second. The Display shows the last reading and the “:” colon symbol.



To switch back to measuring mode:

Press the RECALL / HOLD key once for about 1 second. The tension meter switches back to measuring mode.

6.5 Error Messages

1. The Display shows EEE. The upper limit of the tension range was exceeded by more than 10%. Reduce the line tension.



OR

AUTO ZERO is no longer possible. Recalibrate the instrument following the directions in section 8.0

2. The Display shows -E.E. The lower limit of the tension range was fallen below by more than 10%. Properly insert the process material.

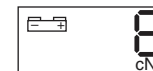

OR

AUTO ZERO is no longer possible. Recalibrate the instrument following the directions in section 8.0.

3. The Display shows the battery symbol. The battery is low and must be replaced immediately. Operating the tension meter with a low battery may cause measurement errors.

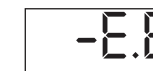

ETMB & ETMPB TENSION METERS



ELECTROMATIC
EQUIPMENT CO., INC.

600 Oakland Ave., Cedarhurst, NY 11516-U.S.A.
TEL: 516-295-4300 • FAX: 516-295-4399